

Bluetooth® Smart Footswitch System

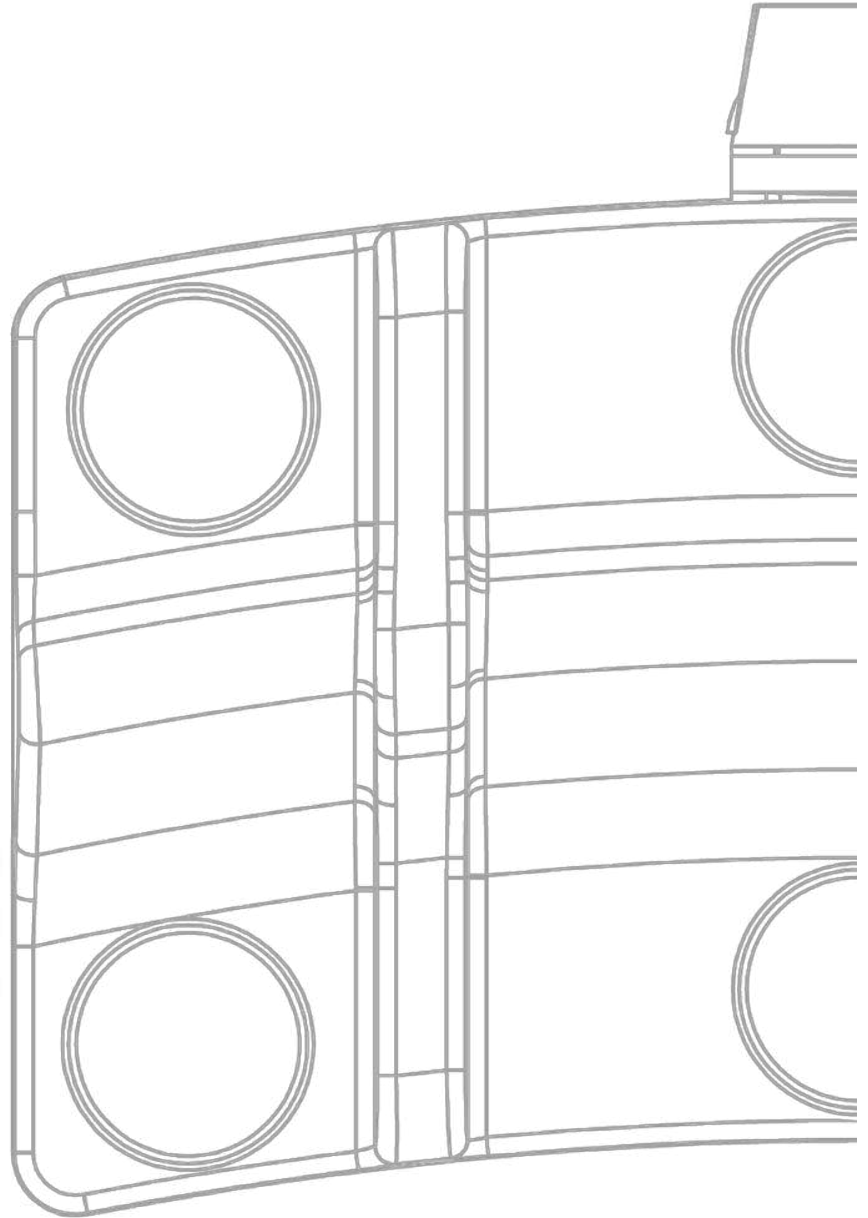

INSTRUCTIONS FOR USE

5604-206

REVISION 05

16 – 12 – 2016

DCR16549

WARRANTY

All footswitches sold by Herga Technology Limited are covered by a 1 year return to base warranty for materials and workmanship from the date of supply.

Our obligation under this warranty is limited to repairing, or at our option, replacing any damaged or faulty components of our equipment, except batteries, without charge providing failure occurs in normal use.

No modifications may be made to the system. The manufacturer shall not be liable for damage caused by unauthorised personnel tampering with the device and consequently any rights to claim under warranty will be nullified.

IMPORTANT NOTICE

Please familiarise yourself with the entire contents of this manual thoroughly before using the Herga Bluetooth® Smart footswitch system, it contains important instructions and information about the safety, use and handling of the product.

Contact Details Herga Technology Ltd
Northern Way Industrial Estate
Bury St Edmunds
United Kingdom
Tel: +44 (0)1284 701422
Fax: +44 (0)1284 753112
sales@herga.com
www.herga.com

Scope These instructions for use apply to the following Herga Products:

- 6311-BLE-xxx (Bluetooth® smart receivers)

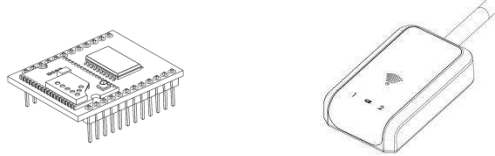

- 6210-BLE-xxx (Bluetooth® smart single pedal footswitch transmitters)

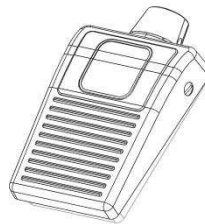

- 6226-BLE-xxx (Bluetooth® smart multi-pedal footswitch transmitters)

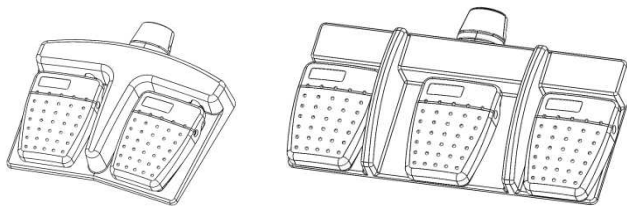

- 6241-BLE-xxx (Bluetooth® smart multi-pedal puck switch transmitters)

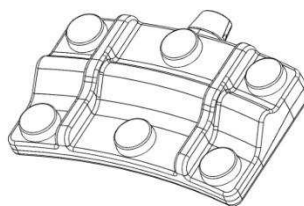

Contents

SAFETY INFORMATION	5
Definitions	5
Hazard symbols	5
Information symbols	5
To the reader.....	5
Intended use	5
Normal use.....	5
WARNINGS	6
PRODUCT OVERVIEW	7
Features	7
Important functionality	7
Network topology.....	8
Electromagnetic Interference.....	9
SET-UP AND INSTALLATION	10
Footswitch.....	10
Cleaning.....	10
Sterilisation.....	11
Pedal allocation	11
Components	12
Battery replacement.....	13
Maintenance	14
Dimensions.....	15
6311-BLE-001 - Receiver	16
Pin Summary	16
Pin Function Descriptions.....	17
Pin 1 - V_{DD}	17
Pin 2 - V_{SS}	17
Pin 3 – 3.3v Output.....	17
Pin 4 - Latency select	17
Pin 5 - Sleep Timeout Select	18
Pin 6 - PWM output.....	18

Pin 7 & 11 - Tx1/ Tx2 Connection Status Outputs.....	19
Pin 8 - Pairing Indication Output	19
Pin 9 - Battery Status Indication Output.....	20
Pin 12 - Reset_n.....	20
Pin 13 - Pairing Button Input	20
Pin 15 & 16 - UART	21
Pins 17 to 24 – Digital outputs.....	24
Typical application circuit	25
6311-BLE-001 Schematic.....	26
Electrical characteristics	27
6311-BLE-001 Dimensions.....	28
Antenna positioning	28
Pairing	29
Un-pairing.....	31
6311-BLE-002 Housed Receiver	32
Dimensions.....	32
Front Panel Features	32
Internal Features	33
Connection Details	33
System States and Troubleshooting	34
PRODUCT AND PACKAGING SYMBOLS	35
Applicable standards	36
FCC/IC Labeling requirements for end product.....	36
Bluetooth® Qualification Information	37
SPECIFICATIONS.....	38
RF Specifications.....	38

SAFETY INFORMATION

Definitions

This section of the instructions for use contains a summary of important information relating to the safe use of the system.

Hazard symbols



A WARNING statement provides important information about a potentially hazardous situation which, if not avoided, could result in death or serious injury.



A CAUTION statement provides important information about a potentially hazardous situation which, if not avoided, may result in minor or moderate injury to the user or patient or in damage to the equipment or other property.

Information symbols



Important Additional information. Should be read carefully.



Denotes a prompt for action.



Denotes an action to be taken.

To the reader

These instructions for use are intended for appropriately trained design engineers that wish to integrate the Herga Bluetooth® smart footswitch system into their product and includes information and instruction on its installation, safe use and maintenance requirements.

Intended use

The Herga Bluetooth® receiver board has been designed to be integrated into OEM electrical equipment.

The Herga Bluetooth® smart footswitch system is considered to be a Programmable Electronic Sub System (PESS) and should only be integrated into medical equipment that is used for applications where a hazardous situation could result in, at worst, a chance of non-serious injury.

The footswitch should not be used as an emergency stop input device.

The footswitch is intended for use by a trained competent person and should not be used by or come into contact with the patient.

Normal use

The Herga Bluetooth® smart footswitch has been designed to be used as an input device for original equipment manufacturers (OEM) electrical equipment.

WARNINGS



Explosion Hazard

- Do not use this equipment in the presence of flammable anaesthetics.

Additional warning for Medical Applications

- Medical environments have high demands for safety and hygiene. The use of inadequate products can cause serious injury to the user or patient.



Additional Recommendations

- Audible or visual indication should be included in the manufacturers system to provide additional operator feedback during switch activation.
- The OEM system manufacturer should provide secondary means to deactivate equipment in the event of a critical failure of this device in a potentially hazardous environment.
- The system manufacturer should isolate mains parts from the receiver by two means of protection.
- The 6311-BLE-XXX series receiver must be supplied by a limited power source according to EN60950-1.
- The OEM system manufacturer should ensure the entire system complies with the state-of-the-art revision of EN 60601-1
- The individual foot pedals used in this system have a recommended life of 100,000 operations. The system manufacturer should design means to count the number of operations and provide warning of obsolescence.
- These instructions must be supplied to the end user or the important points included in the system manufacturers own user manual.
- No modifications may be made to the system. Any modifications may affect the safe use of this system.
- Please report any malfunctions to your Herga Technology representative as soon as you become aware of them.

PRODUCT OVERVIEW

The system consists of three main parts; a battery operated wireless footswitch transmitter, embeddable dual in line package (DIL) printed circuit board (PCB) receiver plus PCB antenna with a U.FL connector for use with the receiver OR a housed receiver with relay outputs.

The momentary operating footswitches are IPX7 rated with 2 LEDs providing indication of pairing and Battery level status and a push button for pairing that is contained within the battery compartment, preventing accidental actuation in normal operating conditions.

The receiver is designed for ease of Integration into OEM machines with robust open collector transistor output stages and status indication outputs that are easily interfaced with push buttons, LED's or with other micro controllers or control circuits.

Features

- Range: Typically 25M (line of sight)
- Up to 8 digital switching functions
- 1 Analogue Input, with PWM or data output.
- Simple secure pairing process.
- Footswitches powered by 2 x AAA commercially available alkaline batteries.
- Over 1000 hours constant use
- Dedicated transmitter connection status outputs (Footswitch & receiver)
- Battery level status indication (Footswitch & receiver)
- EN 60529 Degree of Protection IP67 (Footswitch)
- Custom label options available on request
- Custom pedal colours available on request

Important functionality

- Pairing is carried out once by the user and stored until the user unpairs. The pairing button is housed within the battery compartment to prevent accidental actuation.
- If data is not exchanged for >1 second the system will disconnect and begin indicating via the footswitch LED and corresponding output on the receiver. Re-connection is made automatically.
- If connection is lost while a pedal is pressed the corresponding output will switch off and, upon automatic re-connection, it will not switch back on until the pedal has been released and pressed again.



- If the input power to the receiver is removed, the receiver outputs will be affected and may not correspond to the footswitch status. The system manufacturer should account for this behaviour as part of a risk management process.

Network topology

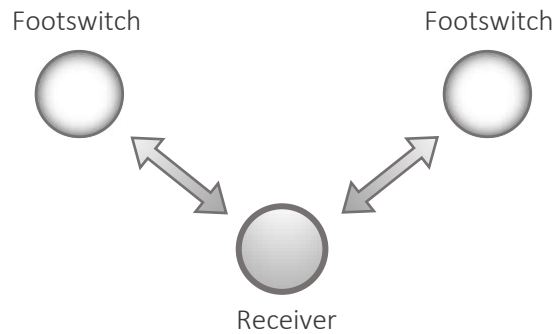

The Herga Bluetooth® smart receiver pairs with a maximum of 2 footswitches and works as a secure closed personal area network. The system operates in the 2.4GHz ISM Band, uses a very secure AES 128 encryption algorithm, and a distributed encryption key procedure.

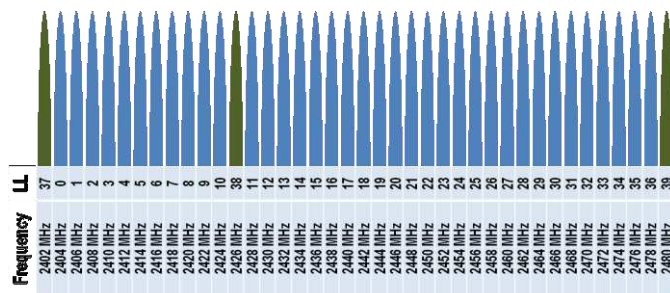

The 2.4GHz band is divided into 40 x 2MHz channels and incorporates adaptive frequency hopping allowing uninterrupted use in the crowded 2.4GHz range.

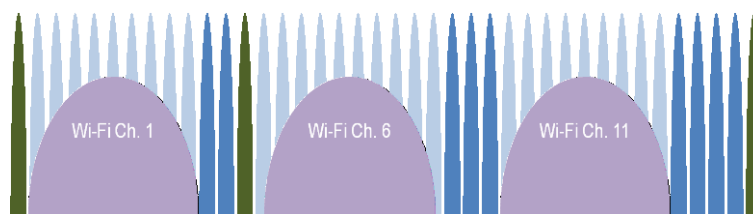

Bluetooth® smart wireless technology has been specifically designed to advertise for device discovery on 3 channels that sit between the commonly used Wi-Fi channels. This allows shorter connection times enabling lower latency when waking from sleep and re-connecting. Nine of the remaining 37 data channels are also located between the three Wi-Fi channels in the 2.4 GHz band. All of these features of Bluetooth® smart wireless technology contribute to a system that has a high tolerance for interference and is very friendly to other wireless technologies in the 2.4GHz band.

Electromagnetic Interference



In addition to the features inherent in Bluetooth® smart wireless technology, and to further help combat interference, a IEC60601-1-2 certified wireless module has been selected. All applicable EMC and radio type approval test reports for the wireless module (including Bluetooth® qualification, ETSI, FCC and EN 60601-1-2) are available on request to help with the customer's approval process.

- Due to the increasing number of radio-frequency transmitting devices and other sources of electromagnetic noise in the health-care and home environments it is possible interference may be caused due to the strength of electromagnetic fields from, or close proximity of, other devices.

This equipment generates, uses, and can radiate radio frequency energy and, if not installed and used in accordance with these instructions, may cause harmful interference with other devices in close proximity. Disruption or interference may be evidenced by erratic or incorrect functioning. If this occurs, steps should be taken to determine the source of this disruption, and eliminate the source. The user is encouraged to try to correct the interference by one of the following measures:

- ➔ Turn equipment in the vicinity off and on to isolate the offending equipment.
- ➔ Reorient or relocate the other receiving device.
- ➔ Increase the separation between the interfering equipment and this equipment.
- ➔ If assistance is required, contact your herga technology representative.

Radio Frequency Exposure

The module contains a small, low power output radio transmitter and receiver. During Bluetooth communication the product receives and transmits radio frequency (RF) electromagnetic fields (microwaves) in the frequency range 2400 to 2500 MHz.

When using the module, you will be exposed to some of the transmitted RF energy. This exposure is well below the prescribed limits in all national and international RF safety standards and regulations.

Electronic Equipment

Most modern electronic equipment, for example, in hospitals and cars, is shielded from RF energy. However, certain electronic equipment is not. Therefore:



NOTE

This equipment emits RF energy in the ISM (Industrial, Scientific, Medical) band. Please insure that all medical devices used in proximity to this device meet appropriate susceptibility specifications for this type of RF energy.

SET-UP AND INSTALLATION



General cautions

This chapter contains information relating to the installation of the system, electrical ratings, and pin functions. The following points should be noted;

- Installation must be carried out by competent trained persons.
- These instructions for use and relevant medical standards, federal, state, local health and safety regulations and codes must be followed.
- Observe the storage and operational temperature range for the device.
- Keep these instructions for use in a safe place for future reference.
- Do not remove the footswitch cover .There are no user serviceable parts inside.

Footswitch



Caution; observe the following battery statements

- Use good quality AAA (LR03) batteries from a reputable manufacturer.
- The system is designed to use Alkaline batteries. Using Lithium batteries will considerably shorten the low battery indication period.
- Remove the batteries if the transmitter is to be stored for prolonged periods of time without use, due to the possibility of battery leakage.
- Do not mix battery technology.
- Do not mix new and old batteries.
- Do not mix battery manufacturers.
- Observe the 'best before' or 'use by' date shown on batteries.
- Follow the battery manufacturer's recommendations for use and disposal of used batteries.
- Do not touch the battery terminals and the patient simultaneously.

Cleaning

Clean regularly and thoroughly to avoid the build-up of hazardous bacteria and dirt. The device should be wiped clean to remove soils e.g. dust, dirt and organic matter using a cloth or soft fabric with a general purpose detergent.

The product can be disinfected using isopropyl alcohol wipes (70%) or immersion in a disinfectant solution (follow manufacturers disinfectant directions).

Note: Chlorine based disinfectants may lead to deterioration of this device.

After cleaning rinse thoroughly under running water and allow water to drain away, shake well and wipe residual moisture from the enclosure.

Carefully hand-dry using non-shredding absorbent cloth, industrial hot air dryer or place into a drying cabinet.

Sterilisation

This product is not supplied sterilised and is not designed to be subjected to sterilisation.

Pedal allocation

Each pedal of a footswitch transmitter corresponds to an output of the receiver.

Figure 2 below can be used to cross reference the footswitch pedal number to the receiver output for the various models of herga Bluetooth® smart footswitches.

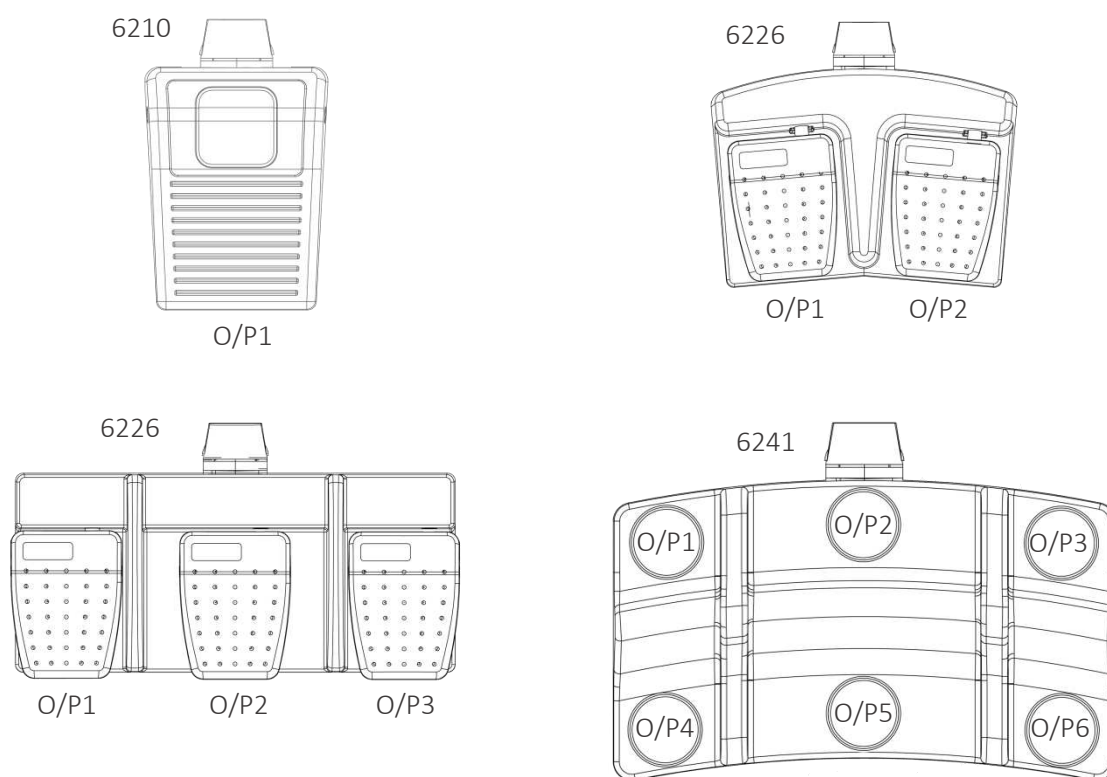
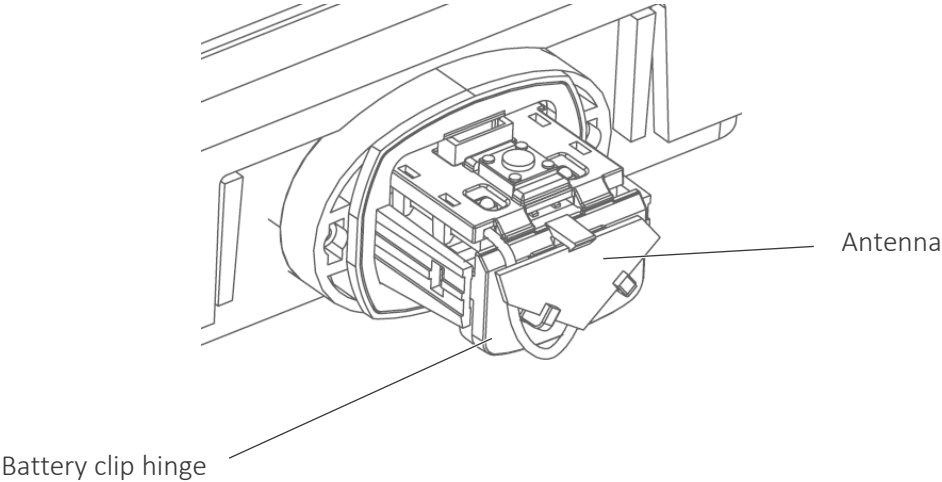
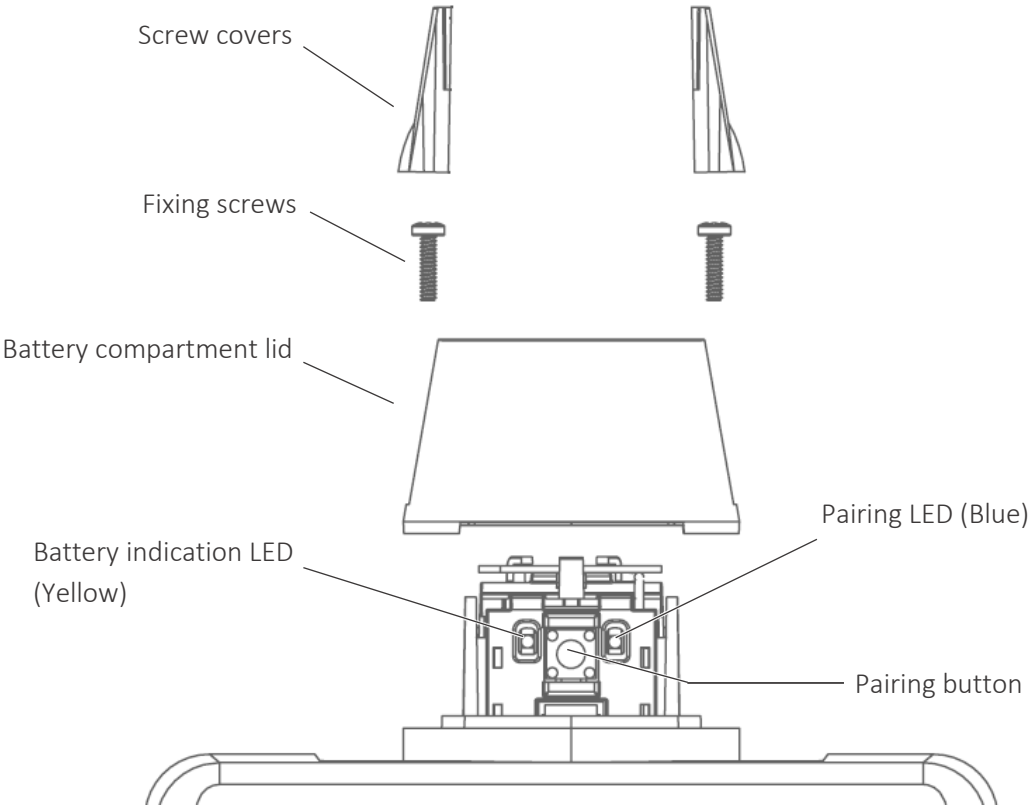
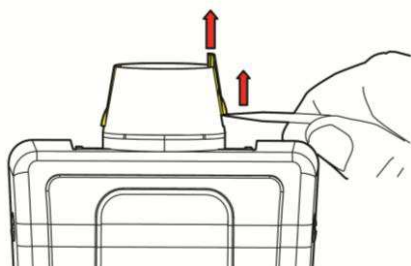

Figure 1) Footswitch pedal number - receiver output reference diagram (Custom variants may differ from that shown.)

Components



Battery replacement



Remove the screw covers using a small flat bladed screw driver or similar

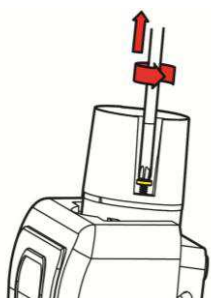

Remove screws using a small philips screwdriver

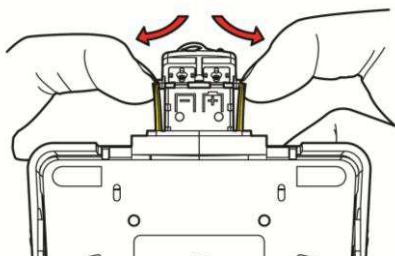

Release the battery clip hinge by firmly but carefully prising the clip posts outwards

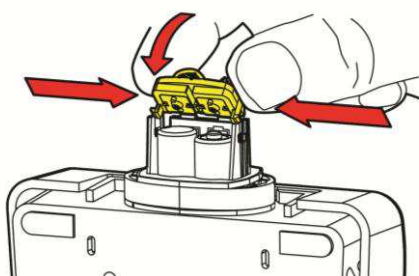

Fit the batteries, taking care to observe the polarity as marked on the PCB , then push the clip back into place by holding the sides of the clip.

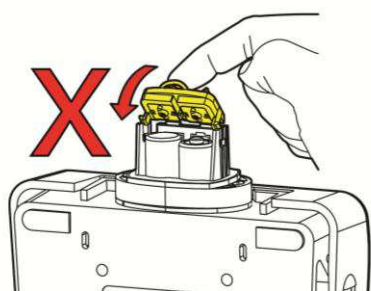

Do not clip back into place by pushing on the antenna.

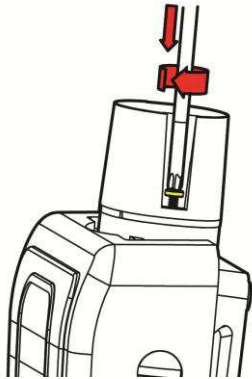

Ensure the gasket is seated correctly, fit the lid then secure in place.

Tighten the screws until the lid fits flush to the enclosure to maintain the IP rating of the battery compartment.

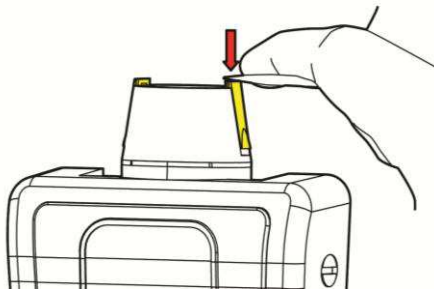

Press the screw covers back into place using the flat part of the flat bladed screwdriver or alternatively loosely fit both covers then press the whole assembly down onto a flat clean work surface.

Maintenance

- Inspect visually and functionally at a minimum of regular weekly intervals to ensure:
 - The device switches on when pressed and off when released.
 - The enclosure has not suffered excessive damage that would present a hazard or prevent switch operation.
 - The pairing LED illuminates as expected when re-connecting.
- Batteries should be changed at a minimum of once a year.
- When changing the batteries visually inspect the gasket for signs of degradation. Gasket degradation indicates compromised IP68 rating of the product. Do not use.
- Do not remove the footswitch covers . There are no user serviceable parts within this area.
- Herga Service Personnel are able to find the software revision listed on the PCBs internal to the housed receiver and Bluetooth® module.

Dimensions

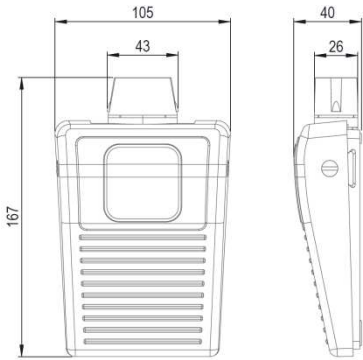
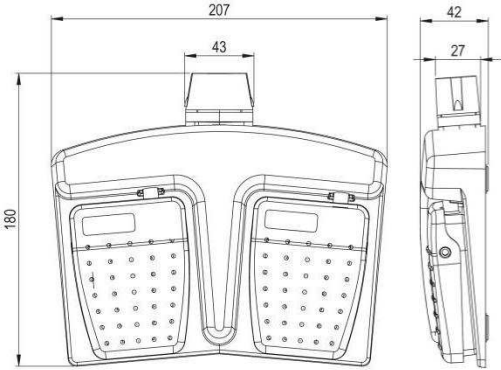
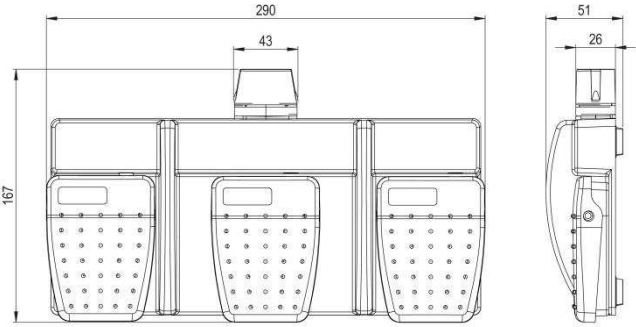
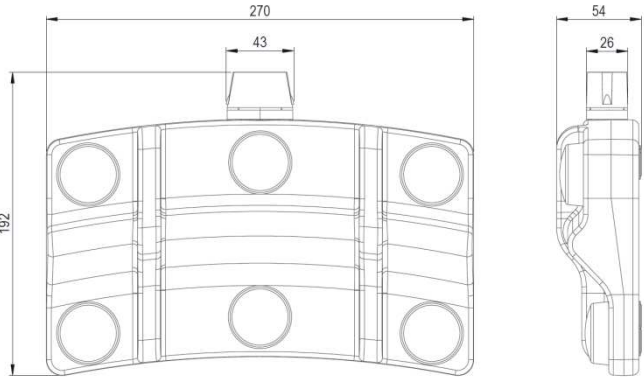
Dimensions	Weight (including batteries)
	0.239 Kg
	0.513 Kg
	1.110 Kg
	4 Pedal variant 0.730 Kg 5 Pedal variant 0.754 Kg 6 Pedal variant 0.777 Kg

6311-BLE-001 - Receiver

The 6311-BLE-001 is an embeddable dual in line package printed circuit board assembly receiver with a U.FL connector suitable for the supplied PCB antenna.

The following sections explain the functionality of the product in more detail.

Pin Summary

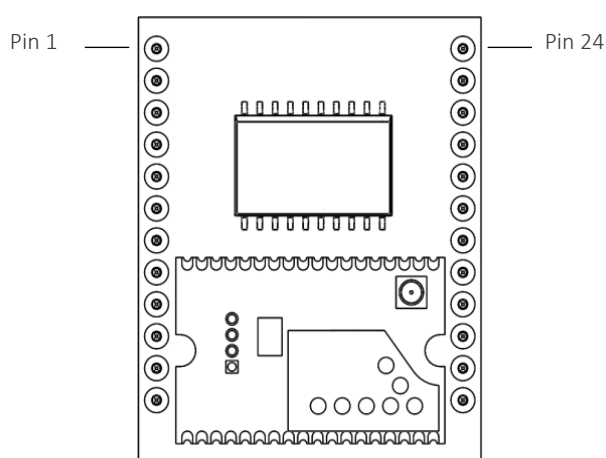

Figure 2) Herga Bluetooth® Smart Receiver Board top view

Pin	Function	Pin	Function
1	V _{DD}	13	Pairing Button Input
2	V _{SS}	14	Reserved, Do Not Use
3	Regulated 3.3vDC output	15	UART Tx
4	Latency Select	16	UART Rx
5	Sleep Timeout Select	17	Output 8
6	PWM (Pulse Width Modulated) output	18	Output 7
7	Tx1 connection status output	19	Output 6
8	Pairing Indication output	20	Output 5
9	Battery status Indication output	21	Output 4
10	Reserved, Do Not Use	22	Output 3
11	Tx2 connection Status output	23	Output 2
12	Reset_n	24	Output 1

Table 1) Receiver Pin Overview

Pin Function Descriptions

The following section describes the function of each pin of the 6311-BLE-001 receiver.

Pin 1 - V_{DD}

Positive supply input pin.

Pin 2 - V_{SS}

Ground reference pin.

Pin 3 – 3.3v Output

A regulated 3.3v output is provided for connection of LEDs to the battery status output, Tx1/Tx2 connection status outputs and for use when interfacing with the UART should it be needed. This output should not be used to power other circuits.

Pin 4 - Latency select

The typical latency is determined by the connection interval of the system. There are two optional settings for the connection interval selected by connecting pin 4 to 0V or leaving it unconnected. This determines the amount of time between pressing a pedal and the receiver output switching on and releasing the pedal and the receiver output switching off.

Table 4 shows the connection details and corresponding latency settings.

Pin 4	Latency (Typical at Nominal 10M range)		
	Off - On	On-Off	Wake from sleep
Not connected (Higher latency)	<100mS	<150mS	500mS
Connected to 0V (Lower latency)	<75mS	<100mS	300mS

Table 2) Latency Selection Table

Latency may be affected by surrounding RF environmental conditions, each application should be examined for the products suitability before installation.

High duty cycle use cases and due to the operating principle of Bluetooth® smart technology, a lower latency setting may result in reduced battery life.



NOTE

The absolute maximum latency of the system in worst case RF environment conditions is determined by the link loss timeout of 1 second.

Pin 5 - Sleep Timeout Select

In the interests of saving power and extending battery life the footswitch will go into sleep mode after a period of inactivity on the inputs.

The user can select how long the period of inactivity is by connecting Pin 5 to 0v or leaving it unconnected. Table 5 shows the connection details and corresponding sleep timeout settings.

Pin 5	Timeout (Minutes)	Pro's	Con's
Not connected	15	Can contribute to longer battery life as sleep mode maybe active more often.	More frequent occurrence of waking from sleep and associated increased latency
Connected to 0V	60	Less frequent occurrence of waking from sleep and associated increased latency	Can contribute to shorter battery life as less time spent in sleep mode.

Table 3) Sleep Timeout Selection Table

Pin 6 - PWM output

Open collector NPN transistor output.

This PWM output has an active low 0-100% duty cycle that is proportional to the position of travel of any herga Bluetooth® smart analogue footswitch paired with the receiver. The effective sampling frequency of the AD input in the footswitch is limited by the connection interval of the system. When using an analogue footswitch it is advised that the lowest latency setting should be used to increase the effective sampling frequency.



NOTE: Possible damage to the device

The intended use of this output is for a control signal into a motor drive circuit, connection to a microcontroller input or similar. It is not recommended that this output directly controls a motor. Electromagnetic interference related to the inductive characteristics of motors may cause unexpected behaviour or damage to the device if directly connected to the PWM output pin.

Pin 7 & 11 - Tx1/ Tx2 Connection Status Outputs

0-3.3V active low outputs current limited to 1.8mA.

Tx1 and Tx2 outputs provide constant feedback of the connections status of any paired footswitches, while the receiver is powered up.

Pin 7	Connection Status of Transmitter 1
Off (High)	No paired device
On (Low)	Paired device awake and in range
Flashing (5Hz 50% duty cycle)	Paired device asleep or out of range

Table 4) Connection status output behaviour

Pin 8 - Pairing Indication Output

0-3.3v DC Active low output. This output is used during the pairing process. Further details of its functionality are explained in following sections of this manual.

Pin 8	Pairing Indication output
Off (High)	No paired device
Flashing (5Hz, 50% duty cycle)	Scanning for a new connection or lost connection
On for 5 seconds (Low)	Unpaired device found

Table 5) Pairing indication output behaviour

Pin 9 - Battery Status Indication Output

0-3.3v DC Active low output. The battery level indication LED/outputs give an indication of three states of battery level. The transmitter with the lowest battery level takes priority. This outputs works simultaneously with the battery LED of the footswitch.

Pin 9	Estimated remaining time
Off (High)	Dependent on usage
Flashing once every 2 seconds	Approximately 1 week constant use
Flashing twice a second	Approximately 2 Days constant use

Table 6) Battery status indication output

 NOTE: the figures above are based on using good quality 1200mAh Alkaline batteries.

Pin 12 - Reset_n

0-3.3v Active low input. Hardware reset pin. Used when changing the BAUD rate (see UART section for further details).

The module must be reset for a Baud change to take effect after the host receives an Ack confirming that the request has been successful.

Pin 13 - Pairing Button Input

0-3.3v Active low input. This input requires an external pull up resistor to 3.3v unless connected to another microcontroller with an internal pull up. The recommended value is 22k Ohm.

It can be connected to a normally open micro switch, push button or to another micro controller or other control circuitry whose output is normally high at 3.3V and switches low.

Alternatively the 3.3V regulated output of pin 3 could be used in conjunction with a transistor to interface with this pin.

Pin 15 & 16 - UART

Pin 15 - The UART Tx is a 0 - 3.3V Input.

Pin 16 - The UART Rx is a 0-3.3 Active low output.

The UART can be used to change the analogue output type from a PWM output to data output. It can also be used to alter the PWM frequency or configure the format of the battery level status indication output. Finally it can be used to configure the baud rate of communication between the receiver and host system.

Various parameters are configurable via the UART, they are:

Configurable parameter	Parameters command code	Parameters options	Parameter setting
Analogue output type	0x61	PWM (default)	0x00
		Data	0x01
Peripheral battery voltage level indication	0x62	Pin out (default)	0x00
		Pin out & Data	0x01
PWM Frequency	0x63	1kHz (default)	0x00
		10kHz	0x01
		20kHz	0x02
Baud (Note: the central must be reset for the baud change to take effect)	0x64	9600	0x00
		19200	0x01
		38400	0x02
		57600 (default)	0x03
Stop Bit	N/A	1 (default)	-
Parity Bit	N/A	None (default)	-

Table 7) UART configuration table

Configuration commands

Data is sent in frames, each frame of is made up of 1 start bit, 8 data bits, no parity bit and 1 stop bit.

Frames are placed into packets and commands are sent with the following packet structure:

Start of packet	Command code	Number of bytes	Parameter setting	End of packet
0x02	See table 6	0x01	See table 6	0x03

Table 8) Command Packet structure

Configuration acknowledgements

The packet shown below is used to acknowledge successful configuration commands and by the centrals host to acknowledge successful receipt of a data packet:

Start of packet	Type	Number of bytes	Data	End of packet
0x02	0x27	0x01	0x06	0x03

Table 9) Ack packet structure

The packet shown below is used to indicate unsuccessful configuration commands and by the centrals host to indicate unsuccessful receipt of a data packet:

Start of packet	Type	Number of bytes	Data	End of packet
0x02	0x27	0x01	0x15	0x03

Table 10) Nack packet structure

Battery voltage level data packets:

The packet structure of the battery voltage level data packets is shown below.

Start of packet	Type	Number of bytes	Data			End of packet
			Byte 1 (Tx ID)	Byte 2	Byte 3	
0x02	0x25	0x03	0 = Tx1 1 = Tx2	High byte	Low byte	0x03

Table 11) Battery voltage reading packet structure

Data bytes 2 & 3 of the packet contain the 10 bit result from the analogue conversion of the battery voltage measurement. These are conveyed in 0.1V steps. Once configured to do so, the battery level readings are outputted once an hour while the battery level is above 2.4V then every 5 mins after that.

Analogue readings data packets:

The packet structure of the analogue reading output is shown below.

Start of packet	Type	Number of Bytes	Data		End of Packet
			Byte 1	Byte 2	
0x02	0x24	0x01	High Byte	Low Byte	0x03

Table 12) Analogue readings packet structure

Data bytes 2 & 3 of the packet contain the 12 bit result from the analogue conversion.

The effective sample rate is determined by the connection interval and results in the following:

1. For the default latency setting (Pin 4 left floating) the sample rate is one sample every 150mS or 6.67Hz.
2. For the lower latency setting (Pin 4 connected to 0V) the sample rate is one sample every 75mS or 13.3Hz.

Pins 17 to 24 – Digital outputs

Open Collector NPN Transistor Outputs. Leave unused outputs unconnected.

Standard footswitch pedals are not interlocked; this means that more than one pedal may be operated simultaneously. Hardwired interlocking of pedals is available upon request, please contact your herga representative for enquires.

Figure 2 below illustrates typical connections to the digital outputs.

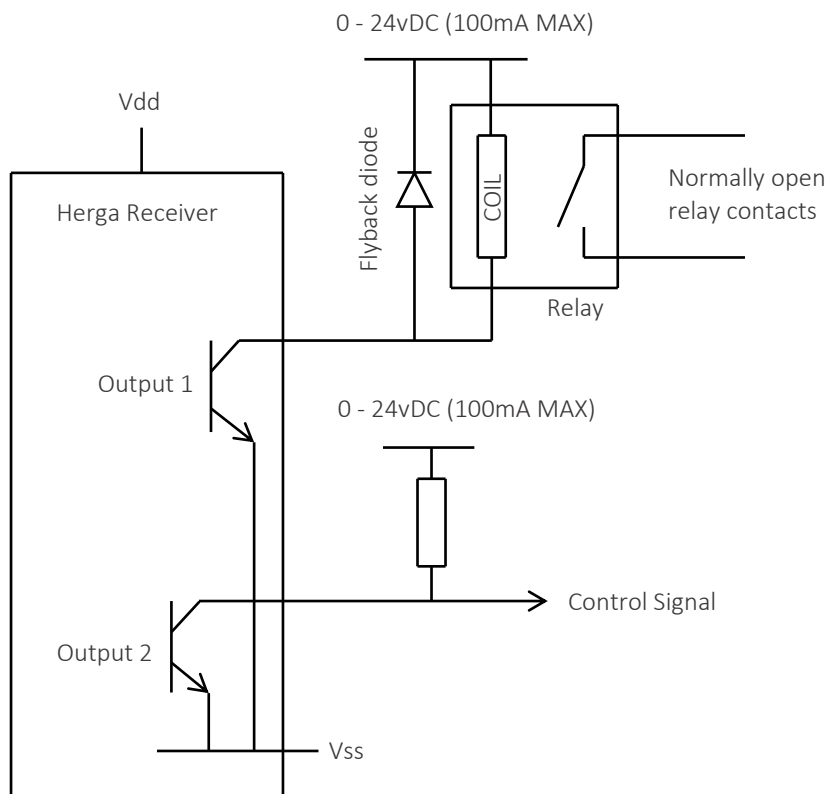
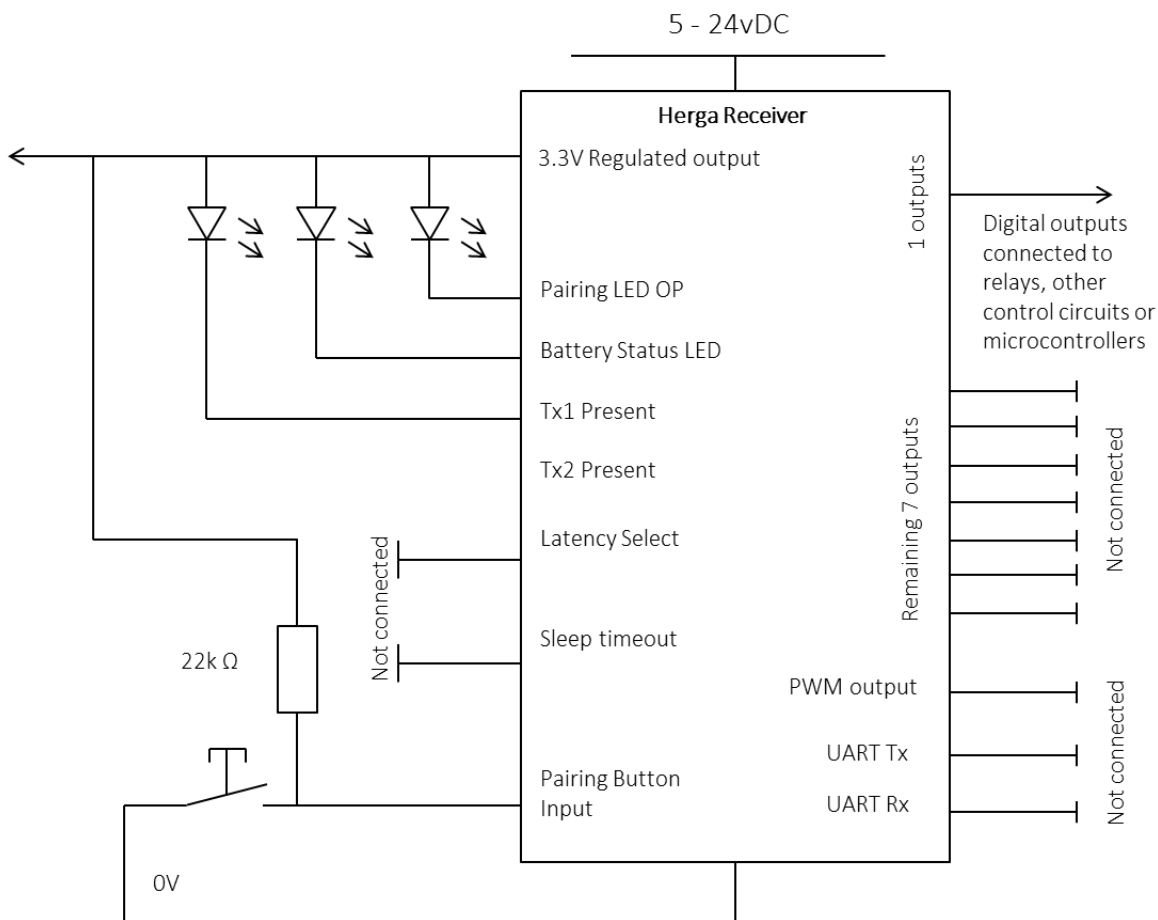

Figure 3) Typical connections to a digital output

Typical application circuit



The circuit above will set up the system for use with single pedal footswitches with the longest Latency Setting (<150mS normal use and <500mS when waking from sleep and re-connecting) with the shortest sleep timeout 15mins.

Pairing is achieved with a push button and indication of the process is via LED. Connection status and battery level status indication is also via LEDs as is the transmitter present indication.

6311-BLE-001 Schematic

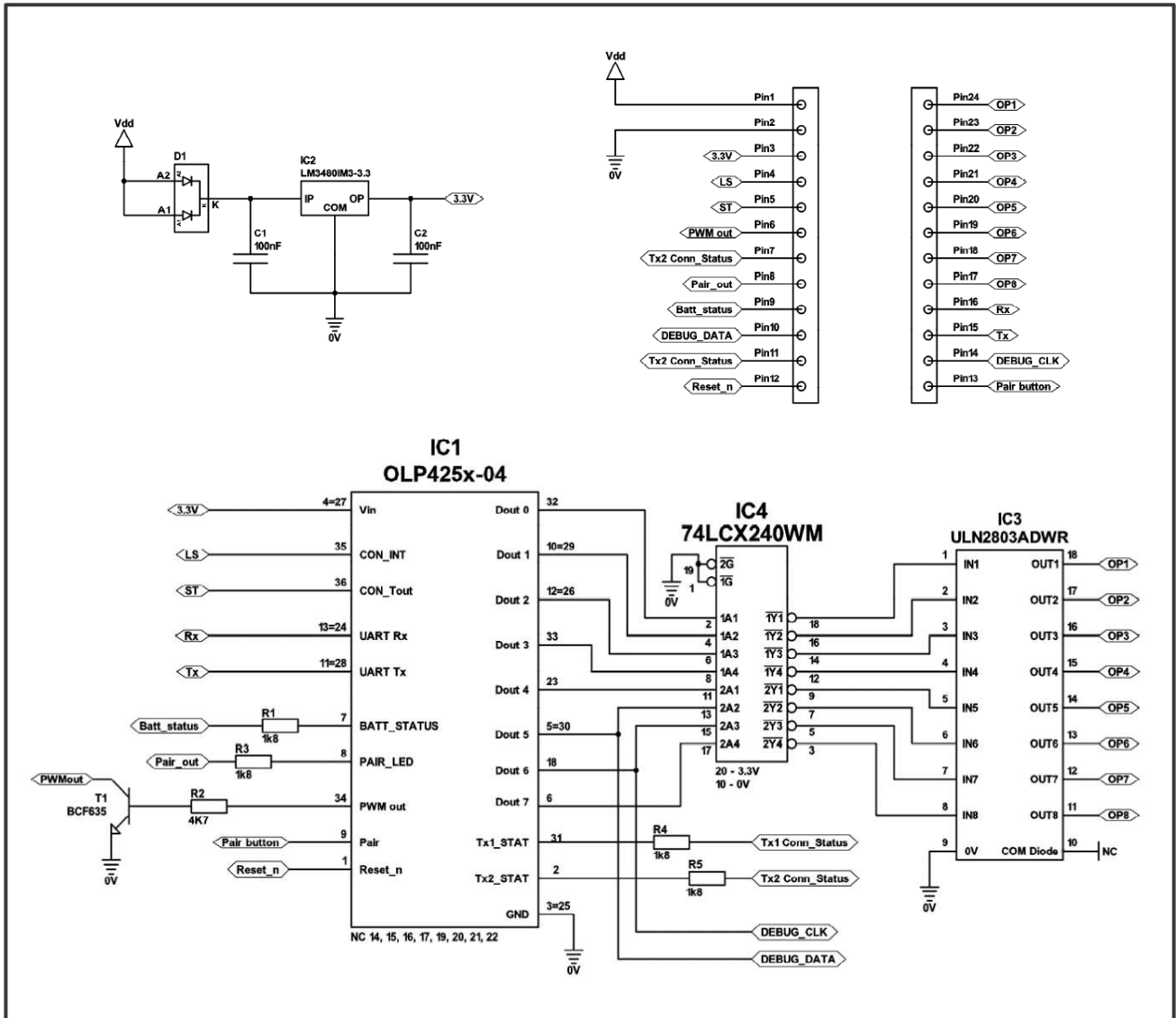

Figure 4) 6311-BLE-001 Schematic

Electrical characteristics

NOTE Possibility of damage to the device

- Do not exceed the Absolute Maximum electrical ratings of the pins. Stresses above the level's listed under 'Absolute Maximum' may cause damage to the device. Prolonged exposure to the Absolute Maximum rating may also cause damage to the device.
- The 6311-BLE-001 PCB receiver must be supplied by a limited power source according to EN60950-1.

Pin Number	Electrical Characteristic	min	max	Absolute maximum	Unit
1	Voltage on V _{DD} with respect to V _{SS}	5	24	35	V
3	Current sourced from 3.3V regulated pin	-	100	100	mA
4	Voltage on latency select with respect to V _{SS}	0	3.3	3.3	V
5	Voltage on sleep timeout select with respect to V _{SS}	0	3.3	3.3	V
6	Voltage on PWM pin with respect to V _{SS}	0	3.3	3.3	V
	Current into PWM pin	0	100	100	mA
7 & 11	Voltage on connection status pins with respect to V _{SS}	0	3.3	3.3	V
	Current sourced from connection status pins	0	2.2	2.2*	mA
8	Voltage on pairing Indication pin with respect to V _{SS}	0	3.3	3.3	V
	Current sourced from pairing indication pins	0	2.2	2.2*	V
9	Voltage on battery status indication pin with respect to V _{SS}	0	3.3	3.3	V
	Current sourced from pairing indication pins	0	2.2	2.2*	mA
12	Voltage on Reset_n with respect to V _{SS}	0	3.3	3.3	V
13	Voltage on pairing button input with respect to V _{SS}	0	3.3	3.3	V
15	Voltage on UART Tx with respect to V _{SS}	0	3.3	3.3	V
	Current sourced from UART Tx	0	4	4	mA
16	Voltage on UART Rx with respect to V _{SS}	0	3.3	3.3	V
	Current sourced from UART Rx	0	4	4	mA
17 - 24	Voltage on output pins with respect to V _{SS}	0	5-24	30	V
	Current into output pins	0	100	500	mA

Table 13) Receiver Electrical Characteristics

*Outputs are internally Limited to 2.2 mA (See circuit diagram for details)

6311-BLE-001 Dimensions

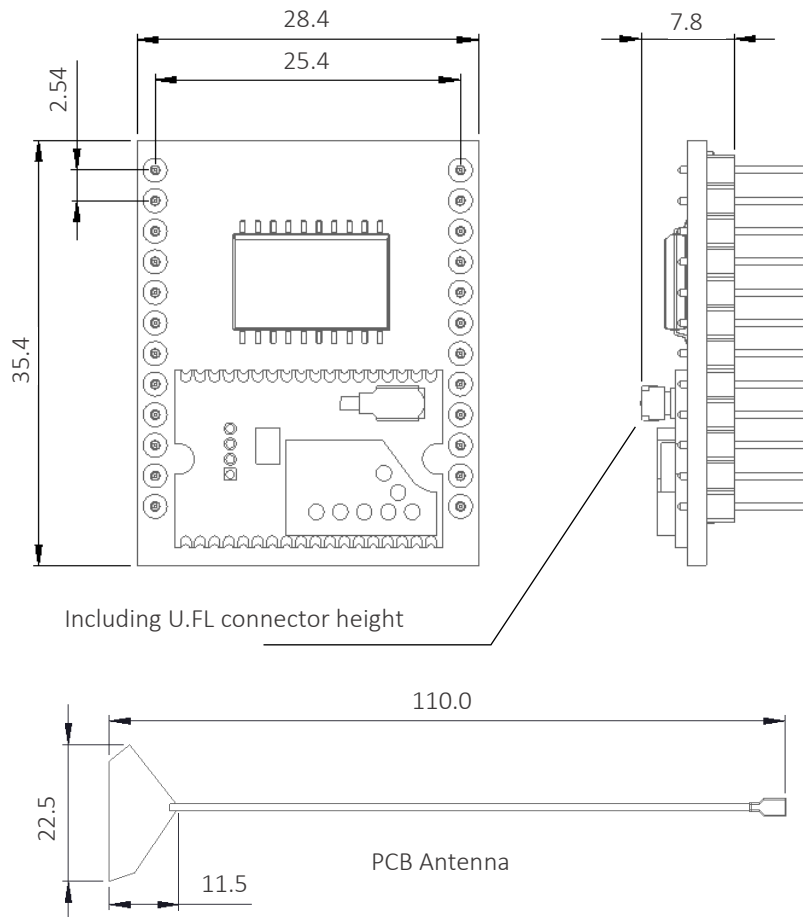

Figure 5) 6311-BLE-001 dimensions

Antenna positioning

The PCB antenna mounting location should be carefully considered since it has an effect on the radio communication quality. Metal casing or plastics containing metal flakes should not be used, avoid also metallic based paint or lacquer. Ideally the antenna should be mounted on the internal face of a plastic external wall of the equipment, alternatively if this is not possible, it may be mounted on a host PCB. Keep an absolute minimum of 10mm free space from metal/copper around the antenna including under and above.

The antenna is provided with a high tact self adhesive pad for mounting

Pairing

All products in the wireless range use the same pairing/unpairing process, as described over the following pages.

1. Press and release the transmitter's pairing button. The transmitter begins advertising for a connection and its blue LED will begin to flash, this will time out after 30 seconds if no further action is taken.
2. Momentarily pulse Pin 13 (the pairing button input) low. The receiver will begin scanning for an advertising transmitter and Pin 8 (the pairing indication output) will flash. This times out after 30 seconds if no further action is taken.
3. Once they have discovered each other the transmitter's pairing LED and the receiver pairing indication output will switch on for 5 seconds.
4. Press and release the transmitter's pairing button a second time to confirm pairing. The transmitter's LED will momentarily pulse off as an indication that the button was pressed. If no action is taken after 5 seconds the pairing procedure will be exited and all outputs switch off.
5. Both LEDs will stay on for a few seconds then flash 3 times to indicate success and the connection status output LED will switch on.

A flow chart is shown in figure 6 on the next page as a visual aid to the pairing process.

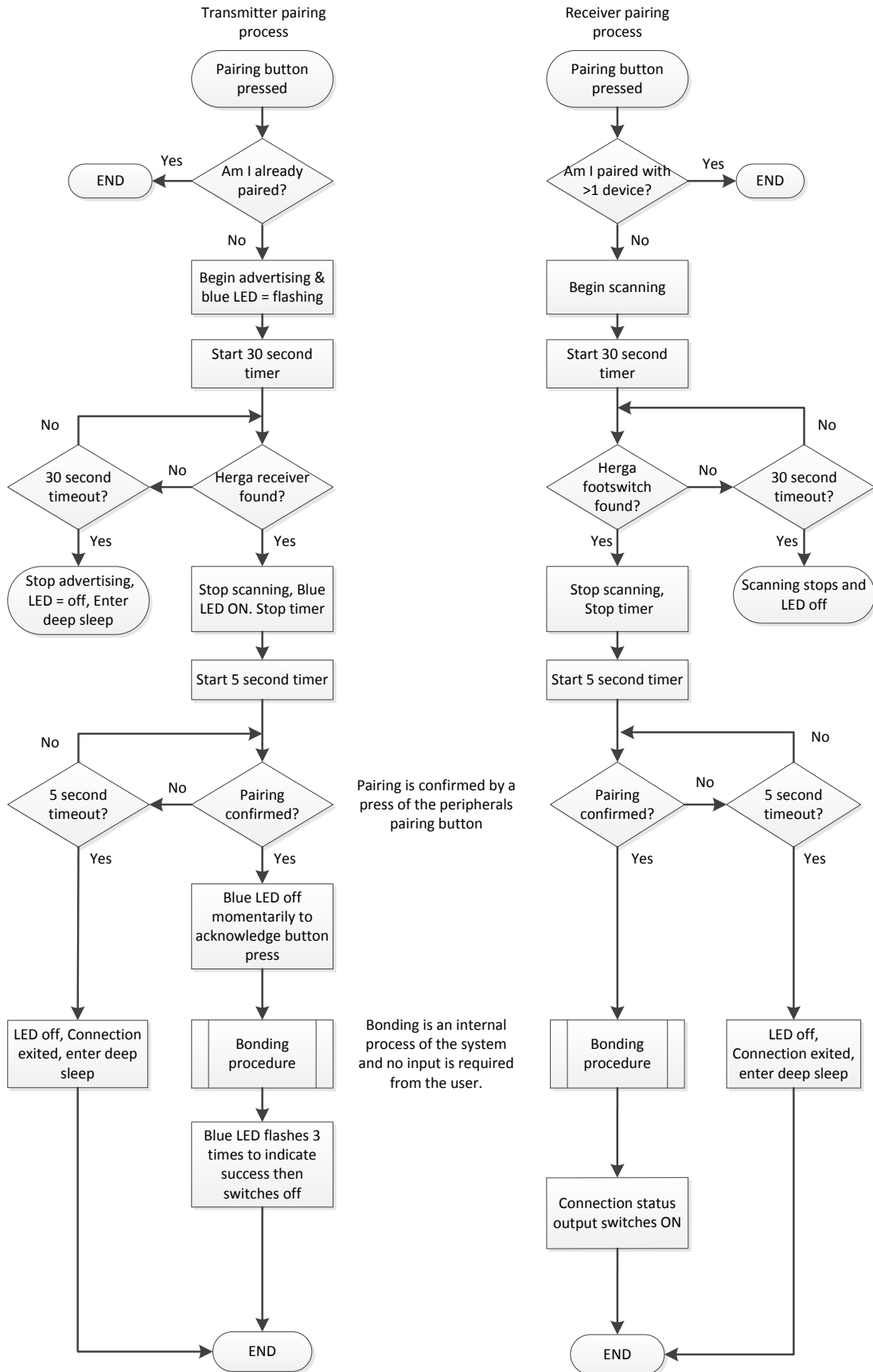

Figure 6) Pairing process flow chart

Un-pairing

If a transmitter needs to be replaced it must be first 'unpaired' or removed from the network. This can be done in one of two ways;

If a transmitter is awake and in range (note that the corresponding connection status output should be on):

1. Press and hold the pairing button on the transmitter you wish to replace for more than 5 seconds.
2. The pairing LED on the transmitter will switch on for 3 seconds.
3. The corresponding connection status output will switch off.
4. The transmitter has been unpaired.

If a transmitter is not working or is lost (the corresponding connection status output should be flashing at 5Hz):

1. Hold the receivers pairing input low for >5 seconds.
2. The corresponding connection status output will switch off.
3. The transmitter has now been removed from the network.



When un-pairing one of two paired footswitch transmitters the other device will be briefly (typically <500mS) disconnected to allow the unbonding, this indicated by its pairing LED, and the corresponding connection status output of the receiver, flashing fast as though scanning for a connection.

Successful reconnection is indicated on the footswitch by its pairing LED flashing slowly 3 times and the receivers corresponding connection status output returning to the ON.

6311-BLE-002 Housed Receiver

The 6311-BLE-002 Wireless Receiver is based around the 6311-BLE-001 PCB assembly and is compatible with Herga wireless transmitters. It has six independent, voltage-free, normally-open relay outputs and one PWM output. LEDs are provided to indicate power, output status, transmitter battery level and connection status of each transmitter.

The device is provided with 300mm of cable and free wire ends. To discuss custom connectors please contact Herga Technology Ltd.

Dimensions

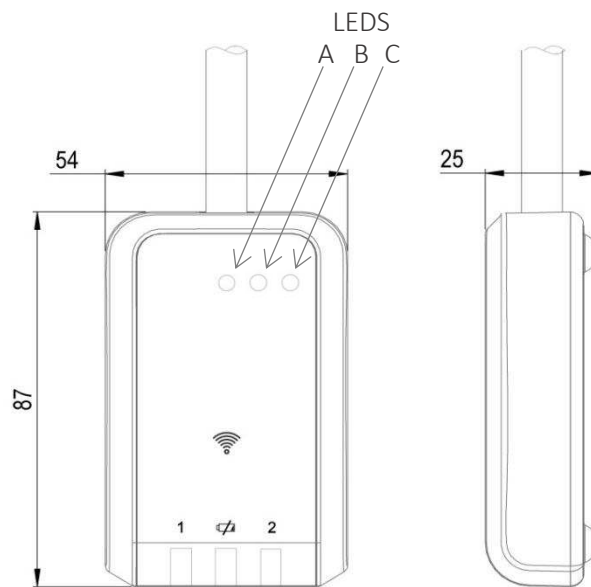

Front Panel Features



Pairing button : Operated by pressing the 'wireless' symbol in the centre of the panel.

1

Transmitter 1 connection status Blue LED



Battery Level Indication Yellow LED.

2

Transmitter 2 Connection status Blue LED

A

Blue pairing indication LED.

B

Blue output activated LED. (illuminates when any transmitter pedal is operated)

C

Orange power ON LED.

Internal Features

Removing the two screws at the rear of the housing reveals a two way miniature switch which has the following functions:

Switch 1 : On = Long time out

Switch 2: On = Short Latency



- The access cover should only be removed during installation!
- No user serviceable parts inside!

Connection Details

Wire Colour	Function	Rating
RED	Positive Supply in	12-24 VDC
BLACK	0V	0V
VIOLET	Battery Indication output	5-24 VDC / 100mA (MAX)
PINK	PWM (Open Collect NPN Transistor)	5-24 VDC / 100mA (MAX)
BLUE	Output 1	1.75A /24 VDC (MAX)
RED/BLUE		
GREEN	Output 2	1.75A /24 VDC (MAX)
GREEN/WHITE		
BROWN	Output 3	1.75A /24 VDC (MAX)
GREEN/BROWN		
YELLOW	Output 4	1.75A /24 VDC (MAX)
BROWN/YELLOW		
WHITE	Output 5	1.75A /24 VDC (MAX)
WHITE/YELLOW		
GREY	Output 6	1.75A /24 VDC (MAX)
PINK/GREY		

System States and Troubleshooting

System State	Possible Cause	Corrective Action
No LEDs illuminated.	<ul style="list-style-type: none"> • Normal operation 	<ul style="list-style-type: none"> • None
Blue LED flashes once when footswitch is depressed	<ul style="list-style-type: none"> • Footswitch has previously entered standby mode but has been awoken by user input 	<ul style="list-style-type: none"> • None
Footswitch blue LED continuously flashing	<ul style="list-style-type: none"> • Footswitch is attempting to pair with receiver • Footswitch is out of range of receiver • Receiver is switched off • Unacceptable levels of electromagnetic interference are in the vicinity of the Bluetooth® system 	<ul style="list-style-type: none"> • If pairing is not currently being attempted, move footswitch closer to receiver, ensure receiver's limited power supply is working or follow instructions in the Electromagnetic Interference section of this document.
Footswitch blue LED solidly illuminated or briefly flashing	<ul style="list-style-type: none"> • Pairing process requires user interaction 	<ul style="list-style-type: none"> • Take appropriate action as described in the Pairing section of this document
Footswitch yellow LED flashing	<ul style="list-style-type: none"> • Battery is low 	<ul style="list-style-type: none"> • Replace batteries (see "Pin 9 - Battery Status Indication Output" for urgency)
Transmitter and receiver do not find each other during pairing	<ul style="list-style-type: none"> • There was a long delay between initiating pairing on the footswitch and receiver • The footswitch or transmitter may be already paired to a different device 	<ul style="list-style-type: none"> • Wait for both footswitch and receiver to timeout then re-start pairing on both sides • Un-pair both footswitch and receiver before re-trying the pairing operation
No LEDs illuminated but depressing Bluetooth® footswitch has no effect on receiver output.	<ul style="list-style-type: none"> • Batteries depleted • Prior reverse-polarity battery connection has damaged transmitter • Footswitch and receiver are not paired/bonded 	<ul style="list-style-type: none"> • Replace batteries • Unpair both sides and re-pair
Output of receiver changes during footswitch press hold or without footswitch being pressed	<ul style="list-style-type: none"> • Connection is lost while footswitch is being pressed • Footswitch batteries are fully depleted 	<ul style="list-style-type: none"> • Move footswitch closer to receiver • Follow instructions in the Electromagnetic Interference section of this document • Replace batteries

PRODUCT AND PACKAGING SYMBOLS



Place of Manufacture



Year of manufacture



Storage and transport temperature range



Storage and transport humidity range



The **W**aste **E**lectrical and **E**lectronic **E**quipment Directive (WEEE Directive) symbol.

EU-wide legislation, as implemented in each Member State, requires that waste electrical and electronic products carrying the symbol must be disposed of separately from normal household waste. Please dispose of in accordance with local bylaws.



Read Instructions for use



CE Mark to indicate conformity only with the Directives applied by the manufacturer (refer to Manufacturer's EC Declaration of Conformity).

If a Notified Body has been involved in the conformity assessment procedure, its identification number is also displayed.



Reference number (Herga product part number)

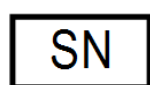

Serial Number (four digit date code followed by four digit unique number)

Applicable standards

A list of applicable standards and directives can be found in the product EC Declaration of Conformity

-  Any changes or modifications to the radio portion of the system could cause the module to cease to comply with FCC rules part 15, and thus void the user's authority to operate the equipment. Only use the antennas supplied by Herga Technology. If you wish to increase range by the use of an antenna with higher gain please contact your Herga representative.

FCC/IC Labeling requirements for end product

-  An end product using the 6311-BLE-001 must include a label containing, at least, the following information:

This device contains FCC ID: PVH0950 IC: 5325A-0950

The label must be fitted to an exterior surface of the end product such that it will be visible upon inspection in compliance with the modular approval guidelines developed by the FCC.

In accordance with 47 CFR § 15.19 the end product shall bear the following statement in a conspicuous location on the device:

"This device complies with Part 15 of the FCC Rules. Operation is subject to the following two conditions; (1) this device may not cause harmful interference, and (2) this device must accept any interference received, including interference that may cause undesired operation."
--

When the device is so small or for such use that it is not practicable to place the statement above on it, the information shall be placed in a prominent location in the instructions for use or accompanying document, or, shall be placed on the product packaging. However, the FCC ID label must be displayed on the device.

Where the final product will be installed in locations where the end-user is not able to see the FCC ID and/or this statement, the FCC ID and the statement shall also be included in the instructions for use or accompanying document.



Bluetooth® Qualification Information

All Herga bluetooth® products are based on the cB-OLP425 Bluetooth® module which has been qualified according to the Bluetooth® specification 4.0 (single mode / Bluetooth Smart)

Module	Bluetooth® Specification	QDID for Controller Subsystem	QDID for Host Subsystem	QDID for Profile Subsystem
cB-OLP425	4.0	BO19409	Bo17183	B019095

The Herga system uses the Generic Access Profile (GAP) service, the Generic Attribute Profile (GATT) and Herga custom application firmware.

The Bluetooth® SIG's "Go To Market Toolkit" guides you through four key steps for success when going to market with a Bluetooth® enabled product:

<https://www.bluetooth.org/en-us/bluetooth-brand/go-to-market-toolkit>

SPECIFICATIONS

Range:	5 - 25M
Battery Life:	1000 Hours constant use
Current consumption (transmitter):	~1uA (Sleep mode)
Quiescent Current consumption (receiver):	~8mA
Receiver outputs:	Open collector NPN
EN60529 Degree of protection (footswitches):	IP67
Working temperature:	+5°C to +30°C
Storage and transport temperature:	-20°C to 65°C (excluding batteries)
Storage/transport and working humidity:	0% to 95%
Maximum operating altitude (air pressure):	5000m (54kPa)
Maximum storage / transport altitude (air pressure):	12000m (20kPa)

RF Specifications

RF Parameter	Data
RF output power	2 dBm + antenna gain
Receive sensitive level	-91 dBm - antenna gain
Antenna Gain	+3dB
Output frequency	2.402 - 2.480 GHz, ISM band.

This device contains:

FCC ID: PVH0950

IC: 5325A-0950

This device complies with Part 15 of the FCC Rules.

Operation is subject to the following two conditions;

- (1) This device may not cause harmful interference, and
- (2) This device must accept any interference received, including interference that may cause undesired operation.

The Bluetooth® word mark and logos are registered trademarks owned by Bluetooth SIG, Inc. and any use of such marks by Herga Technology is under license. Other trademarks and trade names are those of their respective owners.