

- Customer programmable USB footswitch
- Emulates keyboard functions, up to 3 keys simultaneously
- Plug and Play technology, no additional drivers required
- Black cover and base
- 2.5m cable
- Works with Windows™, Linux™ & Mac™
- Mouse and game control functions also available
- Multi pedal versions available on request
- Rated 20mA 5V DC

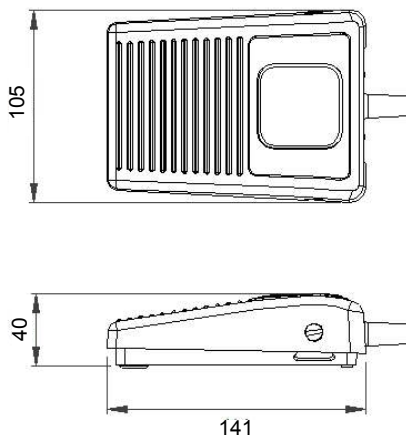

The 6210-0084 is a stock model

## Reference Dimensions



## Accessories

Part Number	Description
6202-0001	Single Black RAL 9005 guard
6202-0002	Single Grey RAL 7035 guard
6202-0003	Twin Grey RAL 7035 guard

