

## For IPX7 single pole switching

- Economic/versatile plastic switch designed to reduce operator fatigue
- Pneumatic version available, please refer to Airswitching section for details
- Ideal for repetitive use with office equipment, domestic/medical appliances and general industrial applications
- Increased temperature range of -20 to +80°C

### Reference dimensions

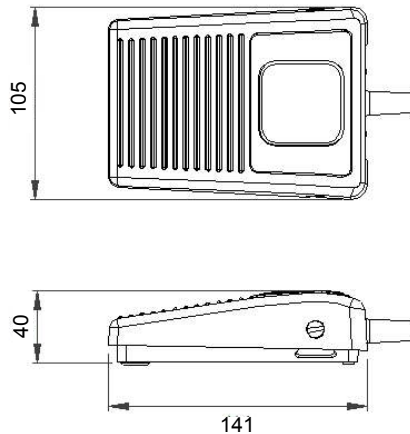

### General specifications

<b>Standards/approvals</b>	Footswitch: low voltage directive 2014/35/EU, EN 60950 Microswitch: EN 61058-2-1, EN 61058	<b>Operating temperature range</b>	-20°C to +80°C
<b>Degree of protection</b>	EN 60529 IPX7	<b>Body material</b>	Thermoplastic
<b>Connection method</b>	2M of black cable with stripped cable cores	<b>Weight</b>	0.375Kg
<b>Electrical rating</b>	Max.3A 250V AC/DC	<b>Additional information</b>	Customised versions available (Logo's, Guards etc.)
<b>Contact configuration</b>	SPCO		

### 6219: Ordering and options

6219 -  Z  B  - Z  B ZZ - 0 0 0

<b>Model</b>	
<b>Cover</b>	A Black B Grey
<b>Switching action</b>	B Single pole change over microswitch (CC)
<b>Electrical rating</b>	A Gold contacts 0.1A 24V AC/DC B Silver contacts 3A 250V AC/DC
<b>Cable</b>	B 2 m black cable
<b>Special attributes</b>	001 through 999 indicates special attributes

### Accessories

Part Number	Description
6202-0001	Single Black RAL 9005 guard
6202-0002	Single Grey RAL 7035 guard
6202-0003	Twin Grey RAL 7035 guard



With 6202 Guard