

Light Duty - Single Footswitch Cost effective range - ex stock delivery

- UL & IEC 60601-1 approved – For medical applications
- Low profile, rear hinged switch designed for improved user comfort
- All plastic construction with raised tread pattern and anti-slip pad
- Versatile and innovative design make it an ideal product for OEM use

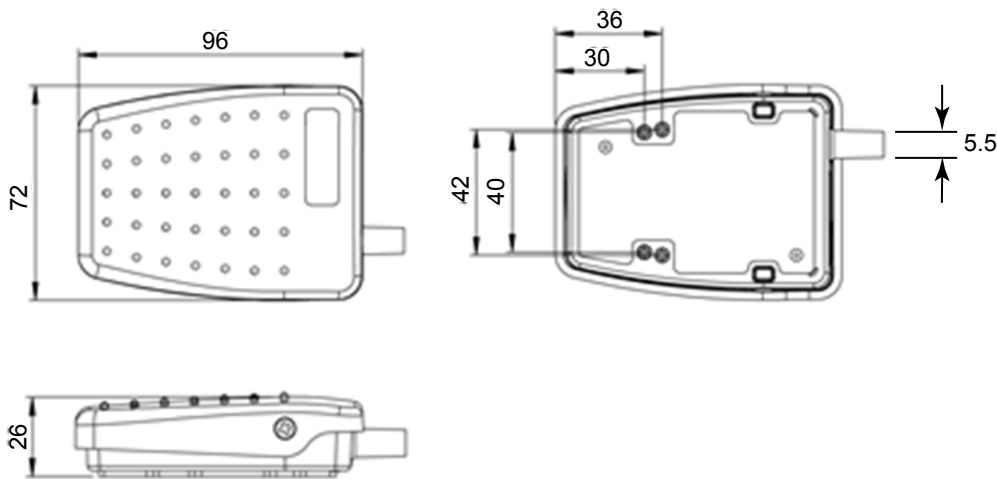

Reference dimensions



6225-ABEB-ZZZA-003 General specifications

Standards/approvals	Footswitch: EN 60950, EN 60601-1:2006, UL 60601-1:2005, ANSI/AAMI ES60601-1:2005/(R)2012, CSA-C22.2 No 60601-1:14, UL File No E353500
Degree of protection	EN 60529 IPX2
Connection method	Solder tag microswitch, no cable fitted (max cable dia. 5.5)
Electrical rating	3A 24V AC/DC
Contact configuration	SPCO (Single pole changeover), Momentary action
Operating temperature range	-20°C to +60°C
Body material	Thermoplastic
Weight	0.12Kg
Additional information	Black cover, black base

Accessories

Part Number	Description
6202-0001	Single Black RAL 9005 guard
6202-0002	Single Grey RAL 7035 guard
6202-0003	Twin Grey RAL 7035 guard



With 6202 Guard