

6241-0058 6-Pedal Bellows Footswitch/Palm Switch

herga

Technology Ltd



- Multi-pedal footswitch, 6- pedal version
- Compact for discrete placement beneath equipment, or for storage
- Robust but aesthetic design
- Soft touch buttons with a light operating force
- Ideal for motion control applications

The 6241-0058 6-Pedal Bellows Footswitch/Palm Switch is supplied with 6 x blue plain domed buttons. The switch is supplied with curly coil cable and an 8 pin din plug. It has IPX7 rating and is designed for operation at 12 V DC at 50 mA.



Reference dimensions

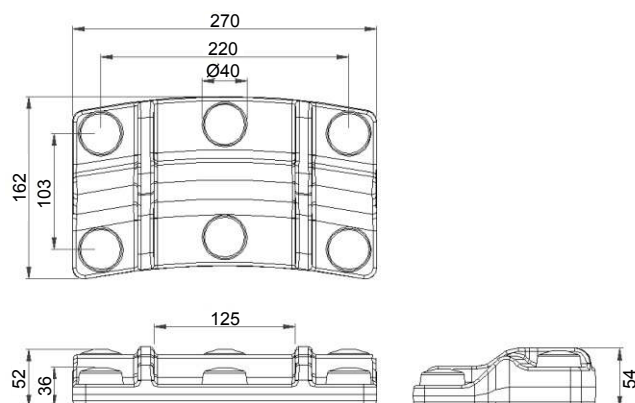

General specifications

Standards/approvals	UL 60601-1 File No. E 207181, IEC 60601-1	Operating temperature range	+10°C to +50°C
Degree of protection	EN 60529 IPX7	Body material	Thermoplastic
Connection method	Curly coil cable with 8 Pin DIN connector	Weight	1.0 kg
Electrical rating	50mA 12V DC	Additional information	choice of colours, logos and labels available
Contact configuration	SPST N/O		