

6241 Bellows Footswitch/Palm Switch

- Lightweight operation over the entire top surface
- Designed to withstand heavy loads
- Customer colours and logos available upon request
- These switches may be used in multipedal configurations – please consult our sales office for your special requirements

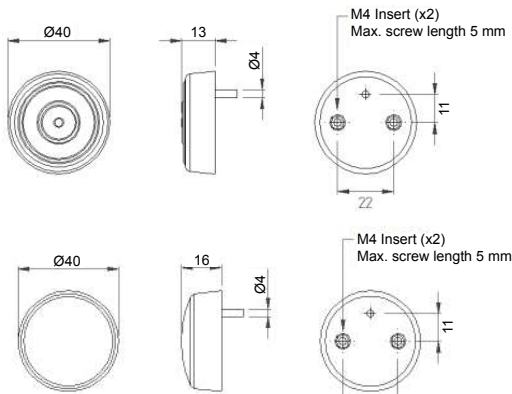

Reference dimensions



Ordering and options

Stock Models : 6241-BAAB-BBAZ-Z
6241-BBAB-BAAZ-Z

6241 - [] [] [] [] - B [] [] Z - Z

Model

Bellows type -

- A Flat
- B Domed

Colour option -

- A Black
- B Grey
- C White
- D Brown/Tan
- E Green
- G Yellow
- H Blue

Fixing option -

- A Back entry base, M4 inserts fitted
- B Back entry base, no inserts fitted
- C Back entry base, No. 4 self tapping screw

Switch action & rating -

- A SPST N/O, 50 mA 12 VDC (operating force <10N)
- B SPST N/O, 50 mA 24 VDC (operating force <10N)
- C SPST N/O, 50 mA 24 VDC (operating force >10N, nom. 15N)

Option C complies with IEC 60601-2-2, IEC 60601-2-38, IEC 60601-2-43 & IEC 60601-2-46 in addition to the standards stated in the specification table
Option C - Only available with domed bellows

Approvals

- B IEC 60601-1 and UL 60601-1

Cordsets

- A 0.22 mm² 2-core black cablez
- B 0.22 mm² 2-core grey cable

Cable length

- A 2 m
- B 3 m
- C 5 m
- D 10 m

General specifications

Standards/approvals	UL 60601-1 File No. E 207181, IEC 60601-1, CSA C22.2 No. 601.1-M90
Degree of protection	EN 60529 IP67 (IP68 upon request)
Connection method	Stripped cable cores or connector of your choice
Electrical rating	see table
Contact configuration	SPST N/O

Operating temperature range	+10°C to +50°C
Body material	Thermoplastic
Weight	0.06 kg
Additional information	Individual buttons are approved only

