

# 6241 Bellows Footswitch/Palm Switch

## Multi-pedal version

# herga

Technology Ltd

# CE US

- Multi-pedal footswitch, 1-8 pedal options
- Compact for discrete placement beneath equipment, or for storage
- Robust but aesthetic design
- Soft touch buttons with a light operating force
- Ideal for motion control applications



### Reference dimensions

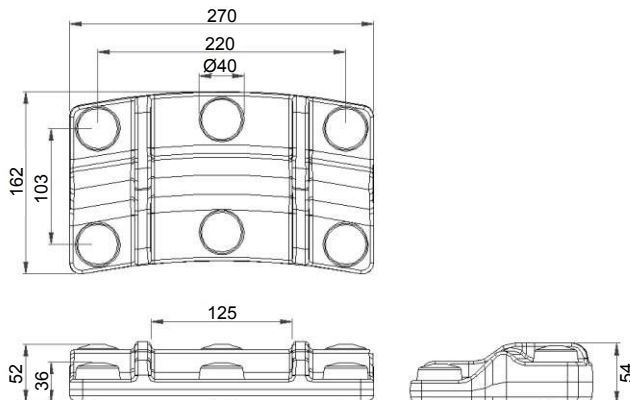

### General specifications

Standards/approvals	UL 60601-1 File No. E 207181, IEC 60601-1	Operating temperature range	+10°C to +50°C
Degree of protection	EN 60529 IP67 (IP68 upon request)	Body material	Thermoplastic
Connection method	Stripped cable cores or connector of your choice, straight or curly coil cable	Weight	1.0 kg
Electrical rating	50mA 24V DC	Additional information	choice of colours, logos and labels available
Contact configuration	SPST N/O		