

6243 Footswitch / Palm Switch

herga

Technology Ltd

- Lightweight operation over the entire top surface
- Designed to withstand heavy loads
- Customer logos available upon request
- These switches may be used in multipedal configurations - please consult our sales office for your special requirements



Outline dimensions

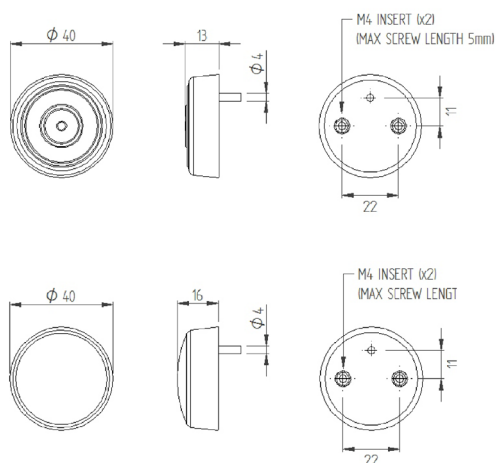

General specifications

Standards/approvals	Low voltage directive 2006/95/EC	Operating temperature range	-5°C to +40°C
Degree of protection	EN 60529 IP67 (IP68 on request)	Body material	Thermoplastic
Connection method	Stripped cable cores or connector of your choice, straight or curly coil cable	Weight	0.06Kg (including cable)
Electrical rating	50mA 24V DC	Additional information	Only available in red
Contact configuration	SPST N/O		
Pressure range	n/a		