

Installation Instructions for 6210-0084 USB Footswitch

- Works with the following OS: Windows™, MAC™ and Linux™
- Third party tested USB 1.1 Compliant.
- Cable length 2.5M
- Extension cables may be used as USB 1.1 is low speed and reliable



The Herga USB footswitch is programmed by the user to simulate up to three simultaneous keystrokes. No software installation is required as it will be recognised by the operating system once plugged into a USB socket. Programming is done simply by setting small switches inside the footswitch having removed the cover (see page 2).

General Specifications

Standards/approvals	USB HID Compliant (no software drivers required)
Power	5V @ 20 mA
Temperature range	10 60° C
Material	Moulded Glass filled nylon plastic construction
Rating	Sealed to IPX2
Weight	395 g

Reference Dimensions in mm

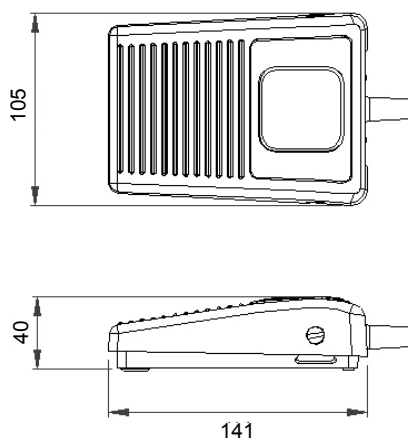

Installation Instructions for 6210-0084 USB Footswitch

Setting the footswitch function

- Release the two hinge screws with a screwdriver turning them a quarter turn and removing them.
- The lid will then come away revealing the switches.
- Find the Key (or combination of keys) you require on the tables below and set SW1, 2 or 3 accordingly.

Key	SW1	SW2	SW3
a	7	2	
b	4	5	
c	3	4	
d	7	4	
e	5	4	
f	7	5	
g	8	5	
h	8	6	
i	5	7	
j	7	6	
k	7	7	
l	7	8	
m	3	6	
n	4	6	
o	5	8	
p	5		5
q	5	2	
r	5	5	
s	7	3	
t	6	5	
u	5	6	
v	3	5	
w	5	3	
x	3	3	
y	6	6	
z	3	2	

Key	SW1	SW2	SW3
1 (!)	1	2	
2 (")	1	3	
3 (#)	1	4	
4 (\$)	1	5	
5 (%)	2	5	
6 (^)	2	6	
7 (&)	1	6	
8 (*)	1	7	
9 (())	1	8	
0 (())	1		5

Key	SW1	SW2	SW3
F1	2	3	
F2	2	4	
F3	6	4	
F4	8	4	
F5	1	1	
F6	8	7	
F7	6	8	
F8	2	8	
F9	2		2
F10	1		2
F11	8		2
F12	4		2

Key	SW1	SW2	SW3
ESC	8	2	
TAB	6	2	
Space	8		1
Enter	3		2
Num Lock	3		1
Win	6		6
Caps Lock	6	3	
↑	8		7
↓	4		1
→	4		8
←	4		7
+	5		7
-	4		9
*	3		9
/	3		8
/?	4		5
Print Scrn	1		4
[{	6		5
]}	6	7	
::;	7		5
~ #	3		5
.>	3	8	
,<	3	7	
_ -	2		5
= +	2	7	
\	8	3	
Back space	6		2
' @	8		5
Calc	6		3

Key	SW1	SW2	SW3
1 End	7		1
2 ↓	7		8
3PgDn	7		9
4 ←	6		1
5	6		8
6 →	6		9
7Home	5		1
8 ↑	5		8
9PgUp	5		9
0 Ins	8		8
. Del	8		9

Key	SW1	SW2	SW3
Page Up	7		3
Page Down	8		3
Home	2		7
End	1		7
Insert	2		8
Delete	2		1

Key	SW1	SW2	SW3
CTRL			10
ALT			11
SHIFT			12

Before replacing the footswitch lid, test the required keystroke function. This is done by plugging the footswitch into a USB port on the PC then pressing the lever on the microswitch SW5.

