

# 6241-0058 6-Pedal Bellows Footswitch / Palm Switch

# herga

Technology Ltd

- Multi-pedal footswitch, 6-pedal version
- Compact for discrete placement beneath equipment or for storage
- Robust and aesthetic design
- Soft touch buttons with a light operating force
- Ideal for motion control applications



The 6241-0058 6-Pedal Bellows Footswitch/Palm Switch is supplied with 6 x blue plain domed buttons. The switch is supplied with curly coil cable and an 8 pin din plug. It has IPX7 rating and is designed for operation at 12 V DC at 50 mA.



## Reference Dimensions

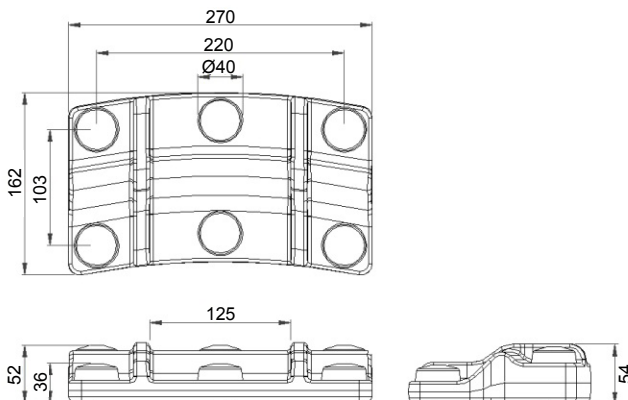

## General Specifications

Standards / Approvals	UL 60601-1, File No. E353500, IEC 60601-1
Degree of protection	EN 60529 IP67
Connection method	Curly coil cable with 8 Pin DIN connector
Electrical rating	50mA 24V DC
Contact configuration	SPST N/O

Operating temperature	+ 10°C to + 50°C
Body material	Thermoplastic
Weight	1.0 kg
Additional information	choice of colours, logos and labels available