

6447 Twin Foot Bellows

- Angled base for ease of use
- Variety of colour options for OEM applications
- Ideal for dirty environments
- Lightweight or heavyweight bases available

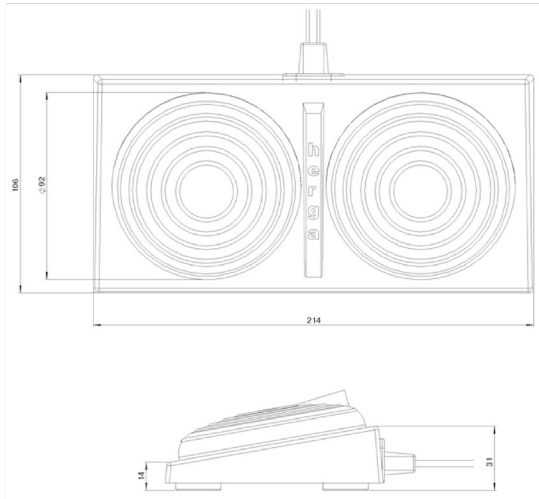

Reference dimensions in mm



General specifications

Standards/approvals	N/A
Degree of protection	EN 60529 IPX4
Connection method	Twin tubing 1.5mm I/D
Electrical rating	N/A
Contact configuration	N/A

Operating temperature range	-10°C to +40°C
Body material	Thermoplastic
Weight	0.3Kg or 0.6Kg
Pressure range	Works with 6871, 6872, 6773, 6753, 6891, 6893, 6861, 6862, 6863, 6864, 6869 – dependent on tube length

6447 Twin Foot Bellows

Ordering and options

6447 - -

Model

Base colour option

- A Grey
- B Black
- C White

Divider colour option

- | | |
|-------------------------------------------|----------------------------|
| A Grey with Herga logo | E White with Herga logo |
| B Grey without Herga logo (plain surface) | F White without Herga logo |
| C Black with Herga logo | |
| D Black without Herga logo | |

Left hand bellows colour

- | | |
|---------|---------|
| A Black | D Red |
| B Grey | E Green |
| C White | |

Right hand bellows colour

- | | |
|---------|---------|
| A Black | D Red |
| B Grey | E Green |
| C White | |

Weight

- | | |
|------------------------|---------------------|
| A Lightweight (0.3 kg) | B Weighted (0.6 kg) |
|------------------------|---------------------|

Tube type

- A Grey twin tubing, straight, 1.5 mm I/D
- B Grey twin tubing, curly coil*, 1.5 mm I/D

*Coiled length 0.9m, extended 2.4m (please select option G from tube length below)

Tube length

- | | |
|-------|-------------------|
| A 2 m | E 6 m |
| B 3 m | F 10 m |
| C 4 m | G Curly coil tube |
| D 5 m | |

Tube identification

- A Green label in heatshrink at the end of the tubing, identifying left hand bellows
- Z No identification provided